

Place SAM 3426T1 profile block on side spindle 2.
 Place SAM 3428T1 profile block on side spindle 3.
 Place 4mm saw blade on side spindle 5, set to produce 4.00mm x15.00mm deep groove.
 Place SAM3428T3 profile block on the first top spindle.
 Place SAM 3428T2 profile block on the second top spindle.

PRINTED COPY UNCONTROLLED

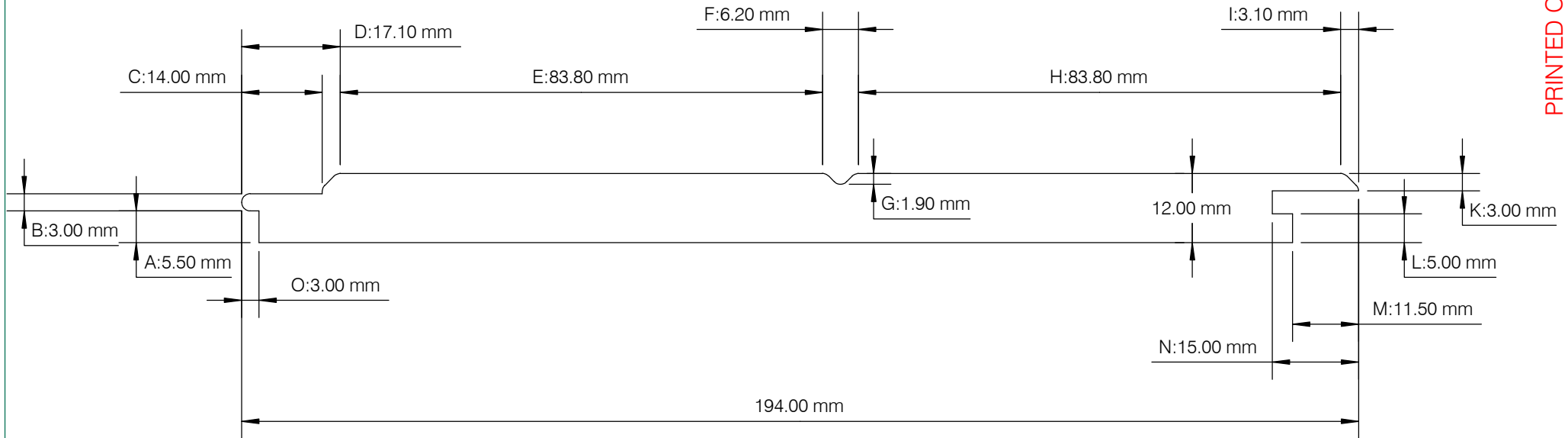

SAM TRIMAX Double TG & V Cladding

MOULDER	ANY
PASSES	1



Newpark Industrial Estate
 Greystone Road, Antrim
 BT41 2RU
 T: +44 (0)28 9442 8288 F: +44 (0)28 9442 8244
 E: team@samonline.co.uk
 W: www.samonline.co.uk

PROFILE	DRAWN BY	Bart Sobecki	REV: 1
SAM 5558	DATE	06/11/2024	AUTH:
	SCALE	1:1	TOLERANCE +/- 0.5MM