

- Place SAM 3426T1 profile block on side spindle 2.
- Place SAM 3428T1 profile block on side spindle 3.
- Place 4mm saw blade on side spindle 5, set to produce 4.00mm x15.00mm deep groove.
- Place SAM3428T3 profile block on the first top spindle.
- Place SAM 3428T2 profile block on the second top spindle.

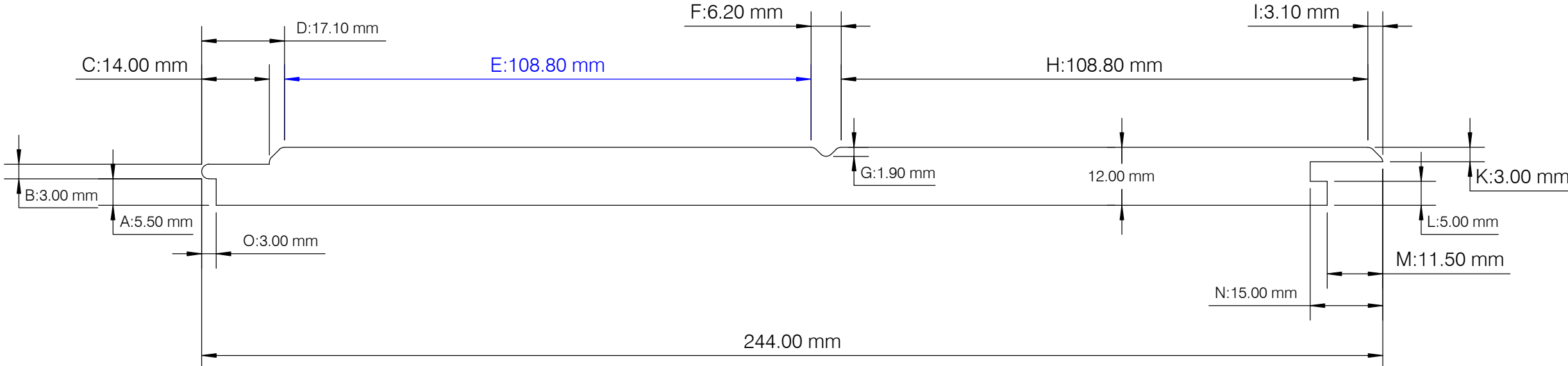

SAM TRIMAX
Double TG & V Cladding

MOULDER	4
PASSES	1
DRAWN BY	Bart Sobecki
DATE	06/11/2024
SCALE	1:1
REV:	1
AUTH:	
TOLERANCE	+/- 0.5MM



Newpark Industrial Estate
Greystone Road, Antrim
BT41 2RU
T: +44 (0)28 9442 8288 F: +44 (0)28 9442 8244
E: team@samonline.co.uk
W: www.samonline.co.uk

PROFILE	DRAWN BY	Bart Sobecki	REV: 1
SAM 5557	DATE	06/11/2024	AUTH:
	SCALE	1:1	TOLERANCE +/- 0.5MM