

Place SAM 01 profile block on side spindle 2.
 Place SAM 24 profile block upside down on side spindle 3.
 Place SAM 27 profile block on the first top spindle.

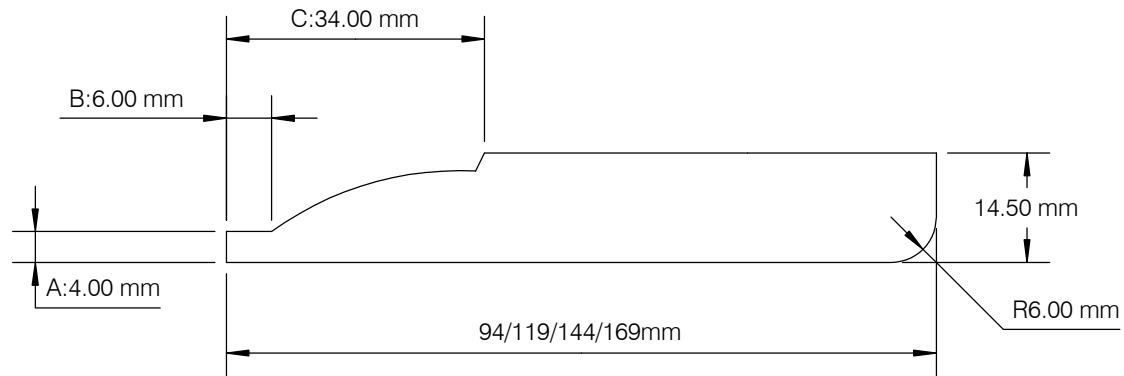

Dual Purpose SAM27/SAM23

PRINTED COPY UNCONTROLLED

MOULDER	ANY
PASSES	1
DRAWN BY	Bart Sobecki
DATE	09/03/2023
SCALE	1:1
REV:	1
AUTH:	
TOLERANCE	+/- 0.5MM



Newpark Industrial Estate
 Greystone Road, Antrim
 BT41 2RU
 T: +44 (0)28 9442 8288 F: +44 (0)28 9442 8244
 E: team@samonline.co.uk
 W: www.samonline.co.uk

PROFILE
SAM 5381