

PCD3012 T1 on e side spindle 2.
 PCD3012 T2 on e side spindle 3.

*THIS PROFILE IS TONGUE AND GROOVE, PROFILE MUST BE CHECKED TO ENSURE THAT BOTH SIDES FIT INTO EACH OTHER!

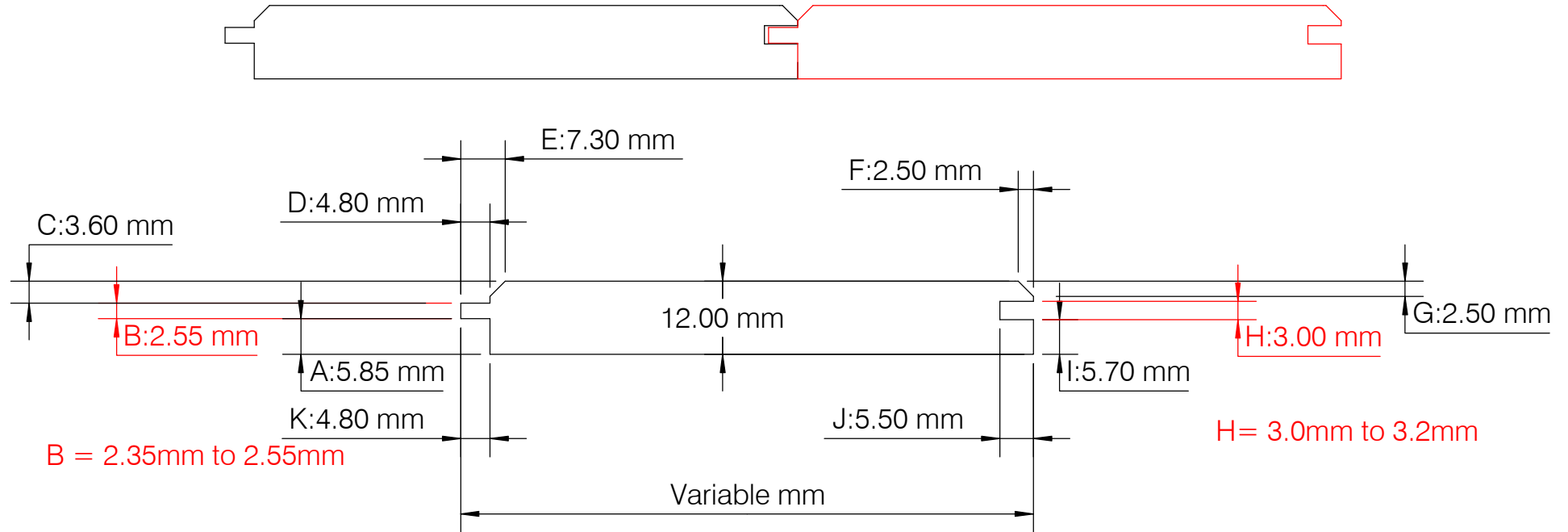

PRINTED COPY UNCONTROLLED

Dimensions in red have a tolerance as stated in text Check DIM H using Grv test template

All others dimensions have a tolerance of +/- 0.20mm, except board thickness which is +/- 0.3mm

MOULDER	ANY
PASSES	1
DRAWN BY	Bart Sobecki
REV:	4
DATE	14/09/2022
AUTH:	
SCALE	1:1
TOLERANCE	+/- 0.5MM



Newpark Industrial Estate
 Greystone Road, Antrim
 BT41 2RU
 T: +44 (0)28 9442 8288 F: +44 (0)28 9442 8244
 E: team@samonline.co.uk
 W: www.samonline.co.uk

PROFILE
SAM 3012