

Place SAM 01 profile block on side spindle 2.
 Place SAM 01 profile block on side spindle 3.
 Place SAM 15 profile block on the first top spindle.

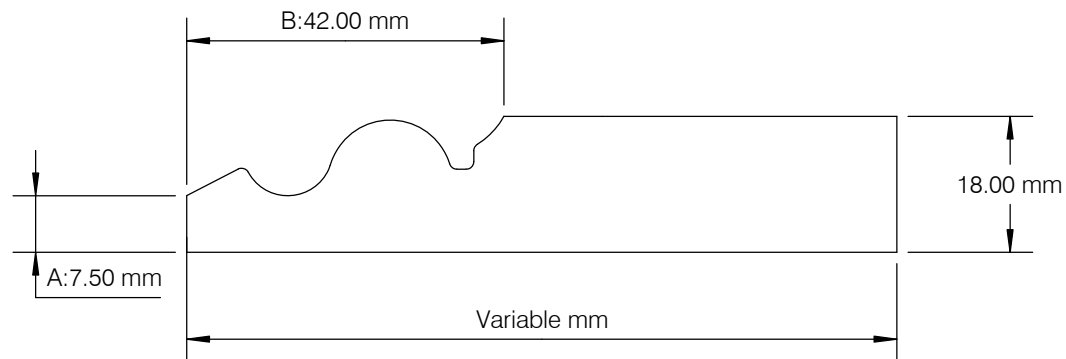
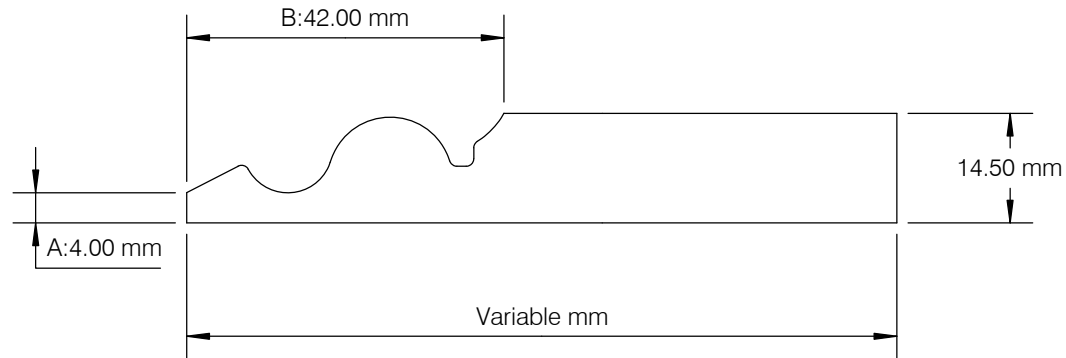

PRINTED COPY UNCONTROLLED

AREA MACHINED AWAY: 236.11 SQMM

MOULDER	ANY
PASSES	1
DRAWN BY	S McMaster
DATE	24/06/2019
SCALE	1:1
REV:	1
AUTH:	
TOLERANCE	+/- 0.5MM

SAM[®]

Newpark Industrial Estate
 Greystone Road, Antrim
 BT41 2RU
 T: +44 (0)28 9442 8288 F: +44 (0)28 9442 8244
 E: team@samonline.co.uk
 W: www.samonline.co.uk

PROFILE

SAM 15

DRAWN BY

DATE

SCALE

S McMaster

24/06/2019

1:1

REV: 1

AUTH:

TOLERANCE
 +/- 0.5MM