

Place SAM 01 profile block on side spindle 2.  
 Place SAM 01 profile block on side spindle 3.  
 Place SAM 97 profile block on the first top spindle.

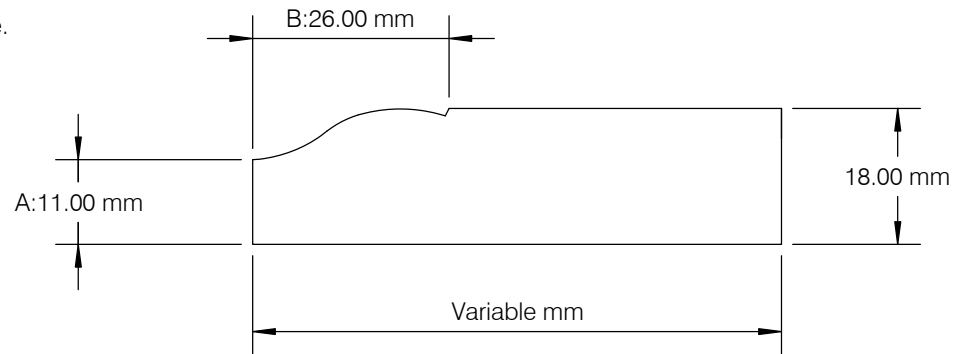

Double version of this profile is SAM 4996

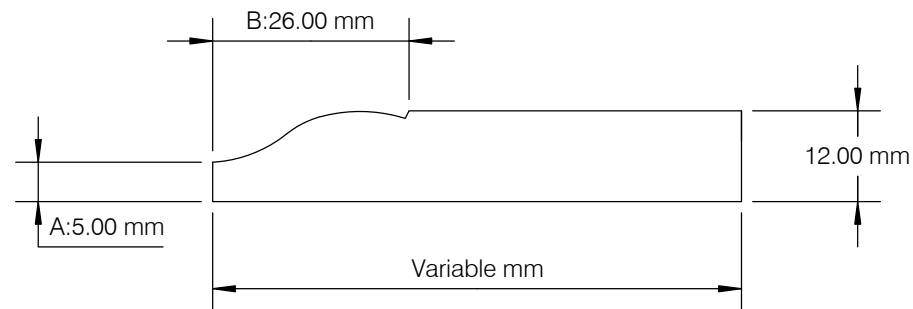
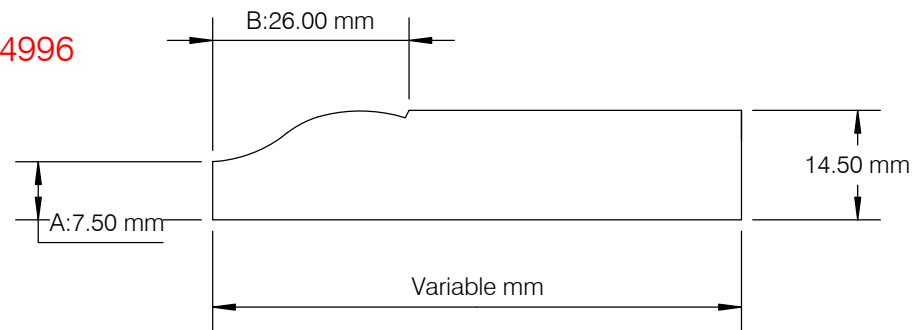

AREA MACHINED AWAY: 65.88 SQ MM

PRINTED COPY UNCONTROLLED

MOULDER	ANY
PASSES	1
DRAWN BY	S McMaster
DATE	17/06/2019
SCALE	1:1
REV:	1
AUTH:	
TOLERANCE	+/- 0.5MM



Newpark Industrial Estate  
 Greystone Road, Antrim  
 BT41 2RU  
 T: +44 (0)28 9442 8288 F: +44 (0)28 9442 8244  
 E: team@samonline.co.uk  
 W: www.samonline.co.uk

PROFILE

SAM 97

DRAWN BY

DATE

SCALE

S McMaster

17/06/2019

1:1

REV: 1

AUTH:

TOLERANCE  
 +/- 0.5MM